



LVDS Grabber/Sender

Grabbing and sending with one device



The Benefits

- ➔ Grabbing, saving and sending of individual images, videos and data
- ➔ Use as LVDS/DVI or DVI/LVDS converter
- ➔ High-performance DLL for implementation of customer-specific requirements
- ➔ Modular set-up making possible an easy adaptation to individual requirements
- ➔ Generation of test images, videos and menu surfaces
- ➔ User-defined configuration of video codecs
- ➔ CAN-link-up (e.g. sending of terminal/lightness telegrams)
- ➔ Stand-alone operation possible

The Product

LVDS Grabber/Sender was developed for testing LVDS control devices and or storing or reproducing image information.

Storage and sender functionalities can be adapted with the help of the flexible platform depending on the OEM customer requirement and operating concept. All required sending/receiving parameters on a PC are adjusted for image transfer with the corresponding PC software.

**RUETZ
TECHNOLOGIES**

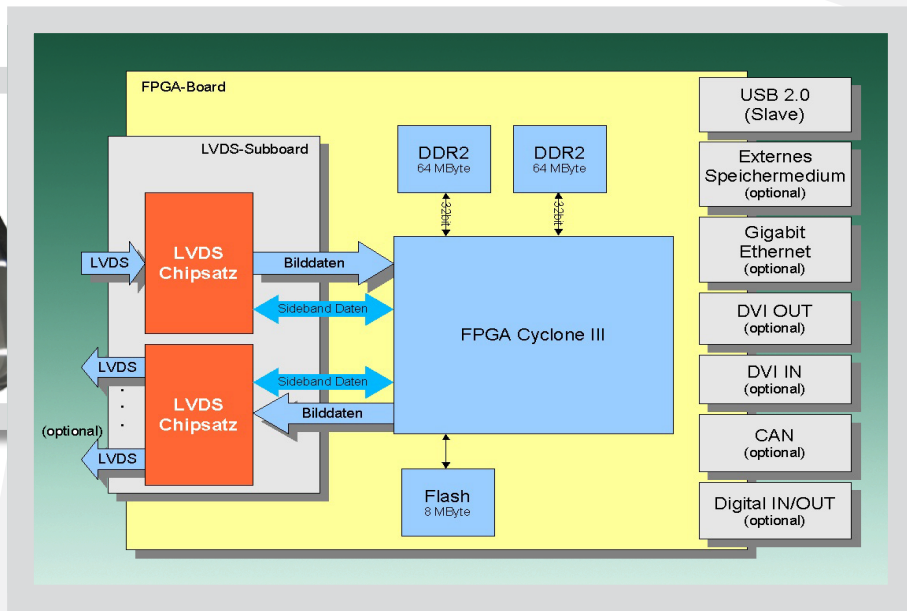

Technical Features

Hardware

- ➔ Compact stand-alone device
- ➔ Power supply 9-16 volt
- ➔ Link-up of sideband channels
- ➔ FLASH 8 MByte
- ➔ 2 x 64 MByte DDR2-SDRAM (Bus width 2x32 bit)
- ➔ External interfaces
 - ➔ LVDS IN/OUT (LVDS subboard)
 - ➔ USB 2.0 Slave (link-up to PC)
 - ➔ 1000-MBit Ethernet
 - ➔ CAN
 - ➔ DVI In/DVI Out
 - ➔ Digital I/O's

Operation as a Grabber

- ➔ LVDS Input/Output (LVDS subboard)
- ➔ Possible looping through of LVDS signal to output
- ➔ Image transmission via USB 2.0
- ➔ Storage on external storage media in stand-alone operation
- ➔ PC Software „SNAPSHOT“ for grabbing images and videos
- ➔ High-performance DLL for implementation of customer-specific testing applications

Operation as a Sender

- ➔ LVDS Output (LVDS subboard)
- ➔ Image transmission via USB 2.0
- ➔ Reproducing of images/videos from external storage media in standalone operation
- ➔ Additional transmission of sideband channels (e.g. SPI, I2C, I2S)
- ➔ Simulation of control devices (sending of telegrams)
- ➔ PC software „LVDS Player“ for sending of images and videos
- ➔ Modular hardware adaptation possible
 - ➔ e.g. 6 x LVDS OUT
 - ➔ Operating elements for stand-alone operation

Optional further developments:

- ➔ Link-up of external storage media for stand-alone operation (Ethernet hard drive /USB stick or SD card)
- ➔ Realisation of individual displays (e.g. menu surface for motor sports)
- ➔ Ability for remote operation via GBIT link up(e.g. synchronous storage and sending of data, remote maintenance)
- ➔ and much more...

RUETZ TECHNOLOGIES GmbH

Dipl.-Ing. Andreas Grey, T +49 / 89 / 35610-175
 andreas.grey@ruetz.de
 Carsten Dörr, T +49 / 89 / 35610-150
 carsten.doerr@ruetz.de
 Walter-Gropius-Straße 17, 80807 München
 www.ruetz.de



**RUETZ
TECHNOLOGIES**